

Description

The BP6211C is a high-performance, high-integration, self-biased synchronous rectifier (SR) with a 60 V MOSFET integrated for flyback converters. It can replace the secondary diode rectifier for higher efficiency and power density.

The BP6211C supports discontinuous conduction mode (DCM), quasi-resonant (QR) and continuous conduction mode (CCM) operations. Robust operation in CCM is enabled with adaptive gate drive and faster turn-off speed with 4 A sink current and ultra-short turn-off delay.

The internal ringing detection circuitry prevents the IC from falsely turning on during DCM or QR operations. The internal turn-on blanking function prevents an accidental turn-off due to parasitic ringing. Ultra-short turn-on delay increases SR MOSFET conduction time to improve efficiency.

The BP6211C generates its own supply voltage without requiring auxiliary winding for low-side or high-side rectification. This feature makes it suitable for charger applications with a very low output voltage or wide output voltage range.

The BP6211C is available in an SOP-8 package.



SOP-8 Package

Typical Application

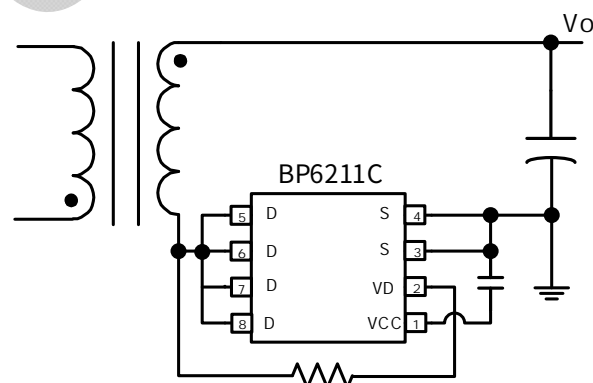

Figure 1. BP6211C Typical Application

Features

- Integrated 60 V MOSFET
- Adaptive gate drive and faster turn-off speed
- Supports DCM, QR and CCM operations
- Ringing detection prevents false turn-on in DCM
- Supports low-side and high-side rectification
- Self-biased and no need for auxiliary winding for high-side rectification
- Supports wide output voltage range down to 0 V
- 4 A sink gate driver prevent false turn-on by the miller effect
- Ultra-short turn-on delay, increase MOSFET conduction time, optimize efficiency
- Low quiescent current
- Compatible with energy efficiency regulations

Applications

- QC, USB-PD and PPS AC-DC Chargers
- High Efficiency Adaptors
- High Efficiency and Power Density Flyback Converters



BP6211C

Fast Turn-Off Synchronous Rectifier for CCM/DCM Flyback Converter

Ordering Information

Part Number	Package	Packing	Marking
BP6211C	SOP-8	Tape & Reel 4,000 pcs/Reel	BP6211C XXXXXXYY ZZZZWWX

Pin Configuration and Marking Information

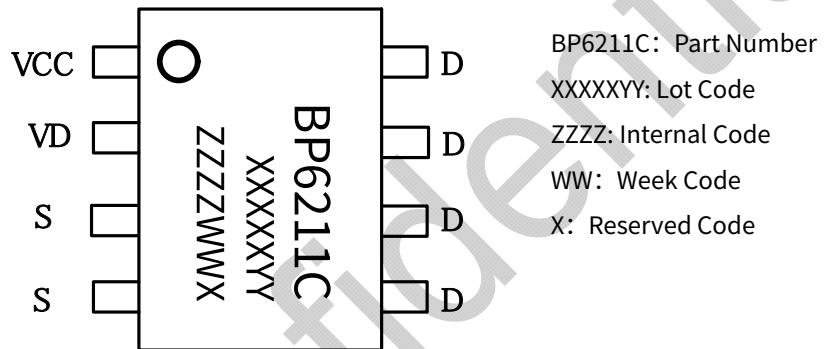

Figure 2. SOP-8 Pin Configuration

Pin Functions

Pin NO.	Pin Name	Description
1	VCC	Linear regulator output. VCC is the supply of the BP6211C.
2	VD	MOSFET drain voltage sensing. VD is also used as the linear regulator input.
3, 4	S	MOSFET source. S is also used as a reference for VCC.
5/6/7/8	D	MOSFET drain.

BP